



## Riva: Lavatesta per parrucchiere

**RIVA**, il nuovo ed inconfondibile lavaggio firmato Luca Rossini, si distingue per uno stile moderno e una linea semplice, senza per questo trascurare la cura dei dettagli: gli eleganti braccioli in alluminio aggiungono al lavaggio raffinatezza e praticità. Confortevole e funzionale, soddisfa le richieste più esigenti ed è la soluzione ideale anche per i saloni più piccoli. Il tocco finale? Il lavaggio Riva è ideato in combinazione con la poltrona da lavoro Diva. Disponibile in bicolore da scegliere su un'ampia gamma di colori senza costi aggiuntivi.

### ARTICOLI

**LR/W030/B** lavaggio con lavabo bianco  
**LR/W030/N** lavaggio con lavabo nero

*Le immagini sono fornite al solo scopo illustrativo e non costituiscono elemento contrattuale*

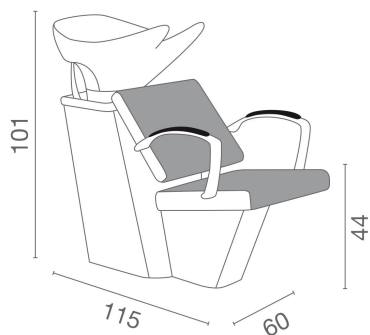

Colori: A  B



Tutti i prodotti Luca Rossini sono disponibili in una vasta scelta di colori senza costi aggiuntivi!



Tutti i prodotti Luca Rossini sono disponibili in una vasta scelta di colori senza costi aggiuntivi!



champagne 10



black coffee 59

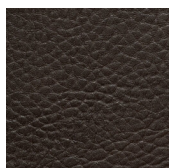

hot chocolate 60



milk 61



tea 62

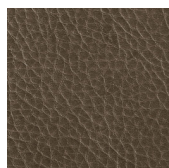

cappuccino 63



espresso 64



light grey G5



dark grey G6

olive G8

royal blue G9

marine L2

chocolate milk K3

strawberry milk K4

gold K6

vintage brown F5



vintage black G1

vintage tan G2

vintage white G3

vintage ash G4

vintage chocolate H9

vintage grey K1

vintage blue K2

vintage wine K7

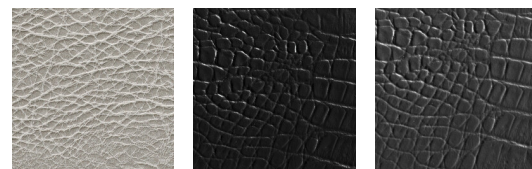

vintage ice K8

black alligator 49

grey alligator 50

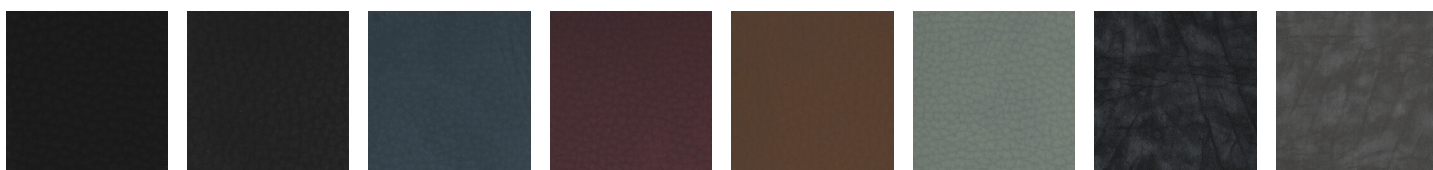

pebble black N1

slate grey N2

peacock blue N3

mulberry N4

cognac N5

sage green N6

black pearl P1

grey pearl P2



brown pearl P3

beige pearl P4

cognac pearl P5

green pearl P6

yellow pearl P7

red pearl P8

pink pearl P9



Via Lazzaretti 12 - 42122 - Reggio Emilia - Italy  
Salon Ambience Italia - +39 0522 276740  
International Sales - +39 0522 276755  
Numero verde - 800 144552  
Fax - +39 0522 276767  
E-mail: info@salonambience.com

<https://www.facebook.com/salonambiencegroup>  
<https://www.instagram.com/salonambiencegroup/>  
[https://www.youtube.com/channel/UCqTdWM-4\\_65Tr0Jul82kSCQ](https://www.youtube.com/channel/UCqTdWM-4_65Tr0Jul82kSCQ)