



Riva+: Lavatesta per parrucchiere

Riva+, l'inconfondibile lavaggio firmato Luca Rossini, si distingue per uno stile moderno e una linea semplice, senza per questo trascurare la cura dei dettagli: gli eleganti braccioli in alluminio - rifiniti da un'imbottitura tappezzata - aggiungono al lavaggio raffinatezza e praticità. Confortevole e funzionale, soddisfa le richieste più esigenti ed è la soluzione ideale anche per i saloni più piccoli. Il tocco finale? Il lavaggio Riva+ è ideato in combinazione con la poltrona da lavoro Diva+. Disponibile in bicolore da scegliere su un'ampia gamma di colori senza costi aggiuntivi.

ARTICOLI

LR/W035/B lavaggio con lavabo bianco
LR/W035/N lavaggio con lavabo nero

IN FOTO: LR/W035/B - COLORE A E B: ALLIGATOR 31

Le immagini sono fornite al solo scopo illustrativo e non costituiscono elemento contrattuale

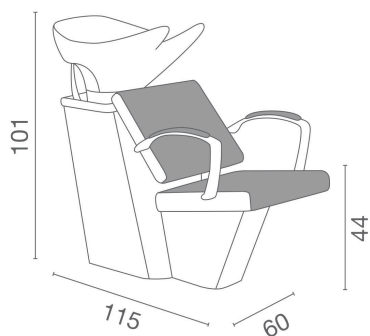

Colori: A B



Tutti i prodotti Luca Rossini sono disponibili in una vasta scelta di colori senza costi aggiuntivi!



Tutti i prodotti Luca Rossini sono disponibili in una vasta scelta di colori senza costi aggiuntivi!



black coffee 59



hot chocolate 60



milk 61



tea 62

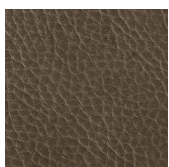

cappuccino 63



espresso 64



light grey G5



dark grey G6



olive G8 royal blue G9 marine L2 strawberry milk K4 vintage brown F5 vintage black G1 vintage tan G2 vintage white G3



vintage ash G4 vintage chocolate H9 vintage grey K1 vintage blue K2 vintage wine K7 vintage ice K8 black alligator 49 pebble black N1



slate grey N2 peacock blue N3 mulberry N4 cognac N5 sage green N6 black pearl P1



grey pearl P2 brown pearl P3 beige pearl P4 cognac pearl P5 green pearl P6 yellow pearl P7 red pearl P8 pink pearl P9

Luca Rossini
MADE IN ITALY

Via Lazzaretti 12 - 42122 - Reggio Emilia - Italy
Salon Ambience Italia - +39 0522 276740
International Sales - +39 0522 276755
Numero verde - 800 144552
Fax - +39 0522 276767
E-mail: info@salonambience.com

<https://www.facebook.com/salonambiencegroup>
<https://www.instagram.com/salonambiencegroup/>
https://www.youtube.com/channel/UCqTdWM-4_65Tr0Jul82kSCQ